

Business Diode GN

Built to last

Laser marking with guaranteed quality

When marking a workpiece, the goal is to apply a permanent, high-contrast, high-resolution identifying mark to it. The impact on the material, along with any changes to its properties, must be kept to a minimum.

Business Diode GN laser systems are the perfect solution for fulfilling these requirements.

To ensure that they will always run smoothly, our products are subject to strict quality control at both the development and the production stage. This guarantees safe, reliable operation from machinery that will stand the test of time.

The functional, compact design of these laser systems is taking industrial laser marking to new places.

CONTENTS

- DPL Nobilis Marker | Page 3
- Features/properties | Page 4
- Applications | Page 7
- Software-based control | Page 8
- Partnership with ACI | Page 9
- Contact details, legal information | Page 10

DPL Nobilis Marker

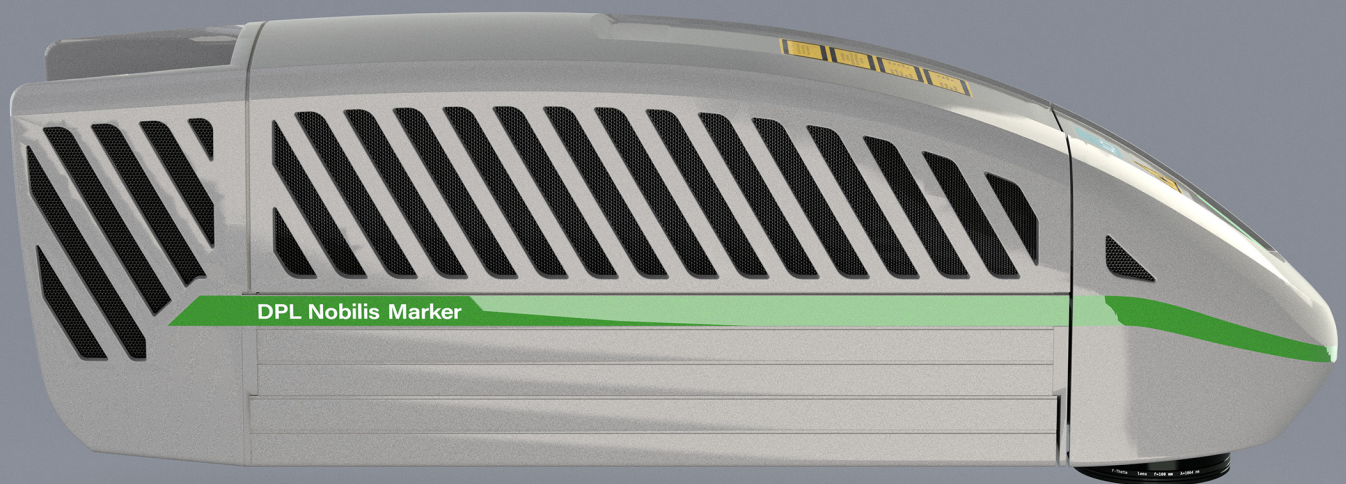

DPL Nobilis Marker

Laser marker for particularly fine processing results

The **DPL Nobilis Marker** from the **Business Diode GN** product series emits laser light in the green wavelength range of 532 nanometres. With many materials, the **DPL Nobilis marker** achieves extremely high-contrast marking results and high processing speeds thanks to its excellent pulse-to-pulse stability and outstanding beam quality. At the same time, the energy of the visible light enables extremely gentle, fine markings.

→ Features/properties

→ Optional features

→ Technical specifications

Features/properties

- Functional safety rating PLe acc. to EN ISO 13849-1
- 100% air-cooled
- Compactness: All of its optical, electronic and mechanical components are integrated into a housing
- High level of operational reliability: No need for external electronic assemblies
- Small dimensions, minimal weight: Easy integration into existing production lines
- Optical focus finder and pre-view function

Including

- Magic Mark V3 marking software
- Code module for generating all common barcodes and data matrix codes (ECC200, QR code, PDF417)
- Programming and communication module for creating customer-specific programs and functional sequences, marking software controlled via external .NET-based programs
- Remote maintenance module

Standard interfaces

- Wide input range of 85–264 V AC
- Eight digital inputs and outputs
- External safety circuit rated PLe
- Interlock connection:
 - Two-circuit interlock
 - SD-ready

Optional features

- Imaging systems for automatic object identification (AOI) and camera-assisted positioning of markings (CPM)
- Code readers
- Different lenses for different marking area sizes
- External USB output e.g. for camera applications

The **DPL Nobilis Marker** is a laser protection class 4 solution. ACI offers the **DPL Nobilis Marker** in conjunction with various protective enclosures for operation in accordance

with laser protection class 1. . This means that these laser systems can be used either as manual workstations or as integration components in an automated system.

DPL Nobilis Marker

Dimensions/view

Laser head

Dimensions (L x W x H)
740 x 201 x 233 mm

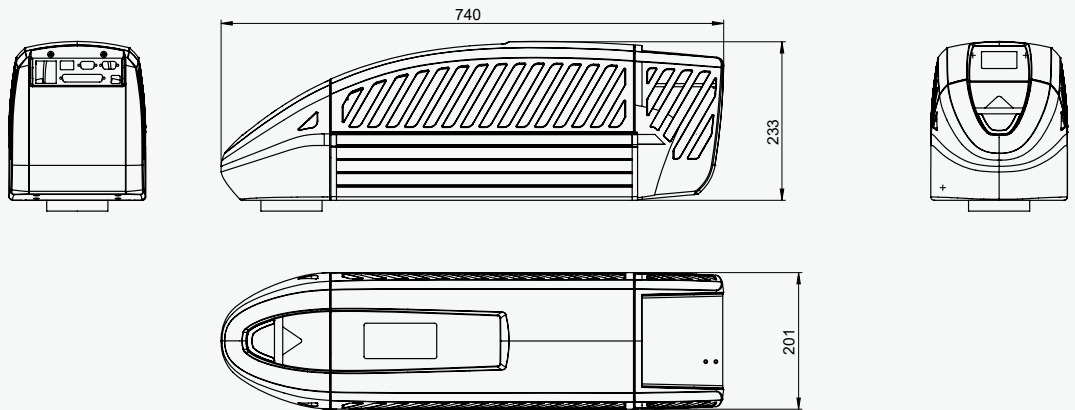

The functional units of the laser marking device include the following assemblies:

- 1 Air cooler for beam source
- 2 Multi-function display
- 3 Lens (laser beam outlet)
- 4 Laser electronics, beam source, beam expander and shutter (beam dump)
- 5 Galvanometer scanning unit
- 6 Power input module and interfaces

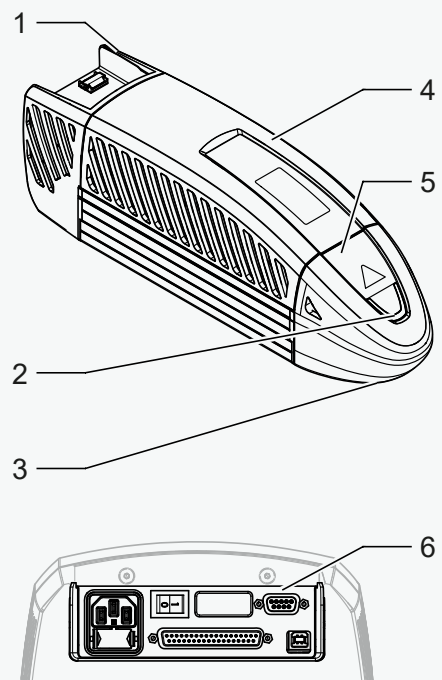

Technical specifications

DPL Nobilis Marker

Laser type	Nd:YVO4, second-harmonic generation		
Laser power (max.)	5 W		
Beam quality (typ.)	M2 < 1.2		
Wavelength	532 nm		
Peak pulse power	Up to 6 kW		
Number of adjustable pulse forms/widths	8–25 ns		
Pulse repetition rate	60–300 kHz		
Laser class	4, optionally 1		
Size of marking area (optional)	50 x 50 mm	100 x 100 mm	160 x 160 mm
Mains connection	85–264 V AC/6 A/50–60 Hz		
Weight	20 kg		
Dimensions (L×W×H)	740 × 201 × 233 mm		
Software	Magic Mark V3		
Interfaces	USB interface, external emission indicator light, signal ready, laser-control interface with eight digital inputs/ outputs, two-circuit interlock connection, SD-ready, power input module, optional connections for encoders		
Functional safety acc. to EN ISO 13849-1	Performance level e (PLe)		

Applications

The **DPL Nobilis** marker can be used to create extremely fine laser markings. The small spot diameter means that there is virtually no thermal stress on the material, meaning that highly sensitive products can be marked gently. At the same time, plastics that barely react or do not react at all to lasers in the infrared range can be marked with high contrast. With the shortened wavelength, many plastics are more reactive, which means that a much better colour change can be achieved. Precious metals such as gold and copper, or other highly reflective materials, can also be processed quickly and precisely with the **DPL Nobilis Marker**.

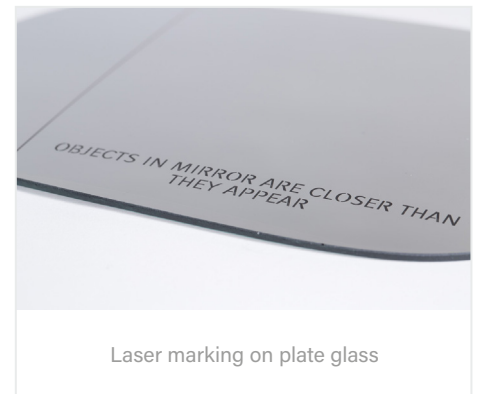
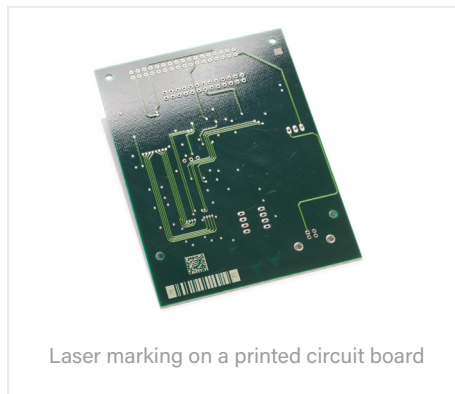
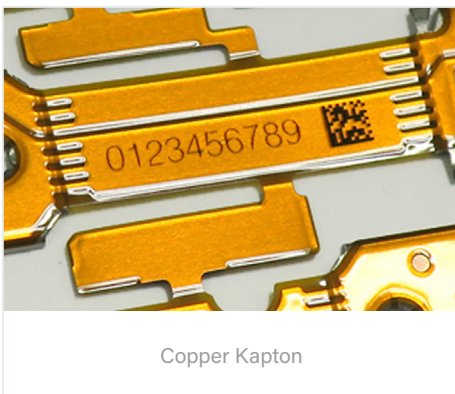
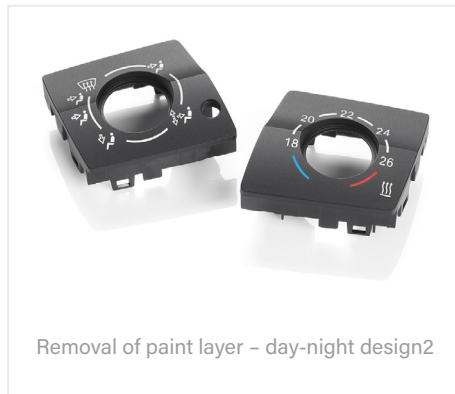

Software-based control

The modern software architecture of the **Magic Mark V3** laser marking software enables targeted access to all available functions and allows users to control the laser and laser peripherals (workstation/axis of rotation, etc.).

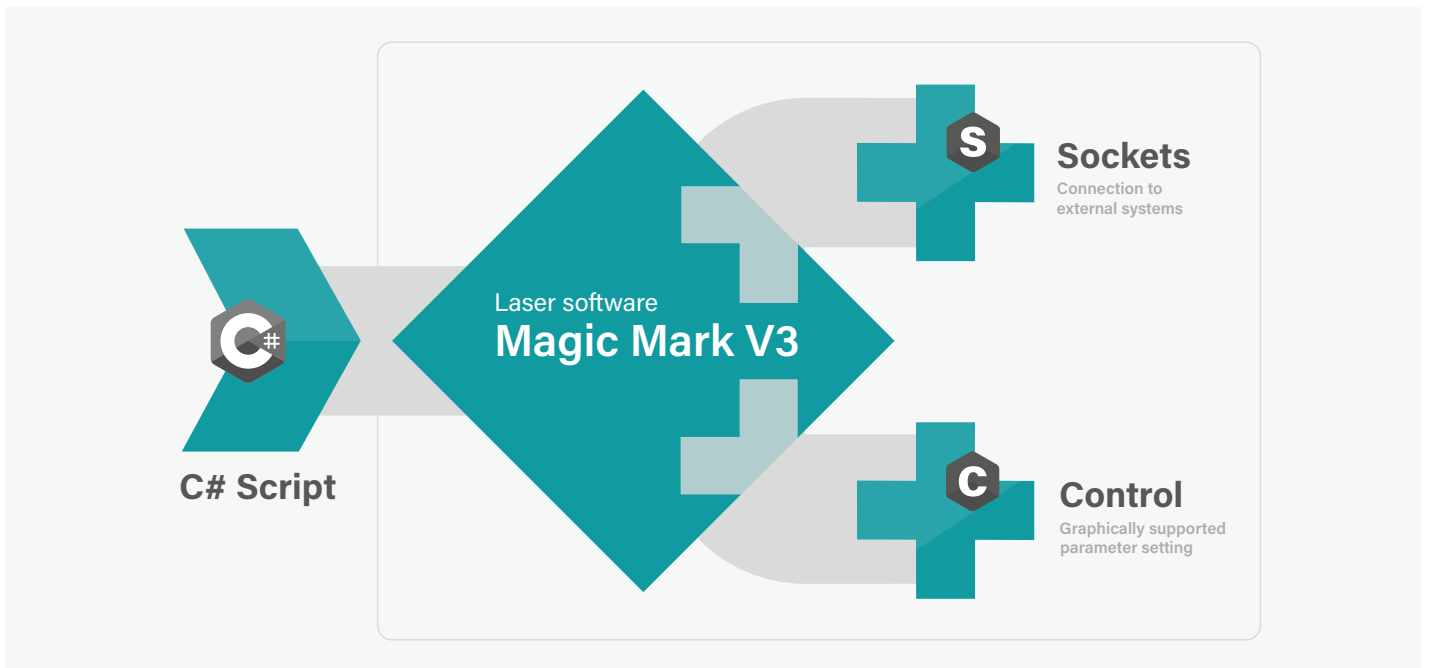

Internal programming

VB.Net [Winwrap Basic]
integrated into Magic Mark V3

External programming

C#.Net [MS Visual Studio]
Access to class library

Benefits of Magic Mark V3

Software package
included in the scope of supply

Predefinable
parameter sets

Easy addition of features
using plugins





Partnership with ACI Laser Benefits for customers

The search for excellent partnerships is at the heart of everything we do. We offer our customers sustainable solutions based on all-encompassing advice, reliability and stability.

ACI Laser embodies:

- ✓ Development & Production that is *Made in Germany* with over 20 years of experience
- ✓ Complete solutions from a single source:
Laser systems, protective housings, software and accessories
- ✓ Customisable laser systems
- ✓ Functions can easily be added to the software using plugins

Made in Germany



We would be happy to advise you.

We guarantee you a tailor-made, all-in-one solution that meets the requirements of your application. Our experienced sales team provides you with comprehensive, in-depth advice. We look forward to hearing from you.

© ACI Laser GmbH
www.aci-laser.de

Last updated: 04/2025
Subject to change

Company headquarters
Steinbrüchenstr. 14
99428 Grammetal, Germany
Tel. +49 (0) 3643 4152 0
Fax +49 (0) 3643 4152 77
kontakt@aci-laser.de

Chemnitz Sales Office
Leipziger Str. 60
09113 Chemnitz, Germany
Tel. +49 (0) 371 238701 30
Fax +49 (0) 371 238701 39
soc@aci-laser.de